

8200 Series Safety Relief Valve

2" MNPT X 2" FNPT H ORIFICE CS

PN: 82H6671311 181-270 psig range

Flanged Dimensions: N/A



**Taylor Valve
Technology, Inc**

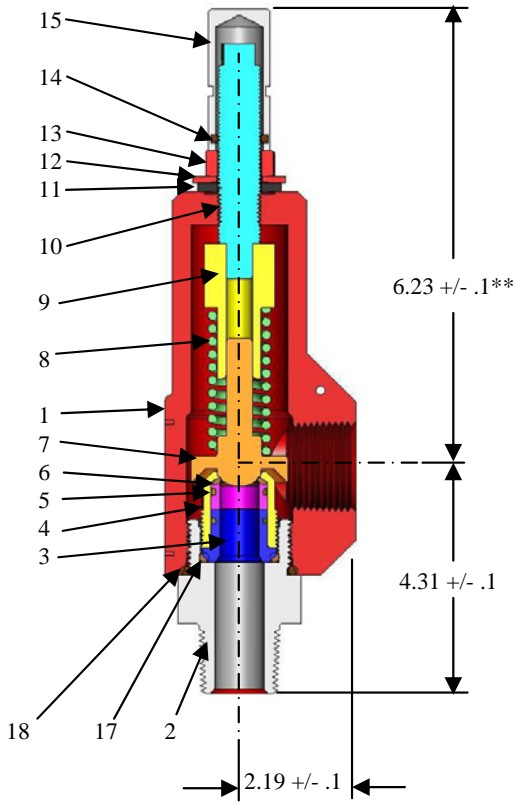

Threaded Configuration

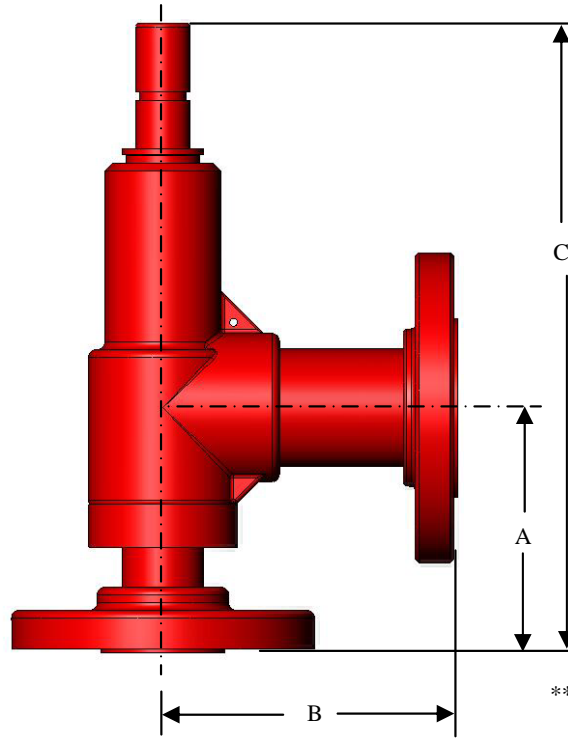

Flanged Configuration

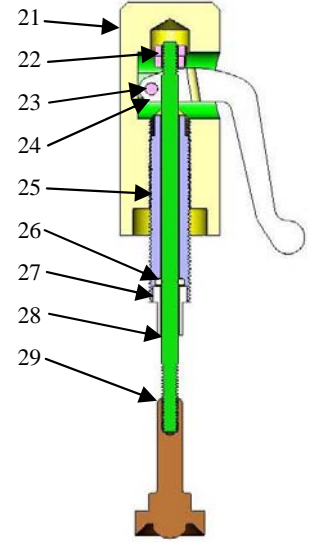

Lift Lever Components

** Lift Lever "C" dimension is 1.6" more

ITEM NO.	QTY.	DESCRIPTION	MATERIAL
1	1	BODY MACHINED SRV1	WCB TO SA216
2	1	SEAT FRAME (INLET)	SA36 CS
3	1	INSERT HOLDER	SS
4	1	SEAT HOLDER BODY	17-4 SS
5	2	O-RING	FKM
6	1	SEAT INSERT	FKM / 303SS
7 ¹	1	DISC SRV1	17-4 H900 A574
8	1	SPRING	17-7 SS
9	1	SPRING KEEPER SRV1	304SS A479
10 ¹	1	ADJUSTMENT SCREW SRV1	CS
11	1	THREAD SEAL	STEEL/BUNA
12	1	FLAT WASHER	PLATED CS
13	1	JAM NUT	PLATED CS
14 ²	1	O-RING 2-214	BUNA
15 ²	1	THREAD PROTECTOR	PLATED CS
16 ³	1	LEAD SEAL 7/16" WIRE TIE 18" 3PLY	SS
17	1	O-RING	FKM
18	1	O-RING	FKM
19 ³	2	DRIVE SCREW 0 X 1/8	18-8SS
20 ³	1	LABEL SRV #2	SS

ITEM NO.	QTY.	DESCRIPTION	MATERIAL
21	1	LIFT LEVER CAP	304 SS
22	2	LOCK NUT	PLATED STEEL
23	1	CLEVIS PIN	SS
24	1	LIFT HANDLE	ALUMINUM BRONZE
25	1	ADJUSTMENT SCREW	17-4 H900 A574
26	1	O-RING	FKM
27	1	O-RING RETAINER	304 SS
28	1	STEM	304 SS
29	1	DISC	17-4 H900 A574

Notes:

¹ These parts are replaced w/ lift lever option.

² Remove these parts w/ lift lever option.

³ These parts are not shown.