

67CF Series Installation Sheet

Introduction

This installation sheet covers the installation and startup of the 67CF Series filter regulators. If maintenance is required, refer to the 67CF Series Instruction Manual, form 5469. Contact your Fisher Sales Representative or Sales Office to receive a copy of the instruction manual.

Specifications

- **Maximum Inlet Pressure:**
250 psig (17,2 bar)
- **Maximum Outlet Pressure:**
50 psi (3,4 bar) over outlet pressure setting
- **Outlet Pressure Ranges:**
0 to 35 psig (0 to 1,4 bar)
0 to 60 psig (0 to 2,4 bar)
0 to 125 psig (0 to 8,6 bar)
- **Temperature Capabilities with Nitrile (NBR):**
-40° to 180°F (-40°C to 82°C)

Installation

WARNING

Personal injury, property damage, equipment damage, or leakage due to escaping gas or bursting of pressure-containing parts may result if this regulator is overpressured or is installed where service conditions could exceed the limits given in the specifications, or where conditions exceed any ratings of the adjacent piping or piping connections. To avoid such injury or damage, provide pressure-relieving or pressure-limiting devices (as required by the appropriate code, regulation, or standard) to prevent service conditions from exceeding those limits.

The internal relief valve in the Type 67CFR regulator does not provide full overpressure protection. The internal relief valve is designed for minor seat leakage only. If maximum inlet pressure to the Type 67CFR exceeds the maximum pressure ratings of the downstream equipment or exceeds the maximum allowable outlet pressure of the Type 67CFR, additional overpressure protection is required.

1. Regulator operation within ratings does not preclude the possibility of physical damage from external sources

or debris in the lines. Regulators should be inspected for damage periodically and after an overpressure condition.

2. Only personnel qualified through training and experience should install, operate, and maintain a regulator. Make sure there is no damage to or foreign material in the regulator and all tubing/piping is free of debris.

3. Install the regulator so that flow is from the IN to the OUT connection as marked on the regulator body.

4. For best drainage, orient the drain valve (key 2) to the lowest possible point on the dripwell (key 5). This orientation may be improved by rotating the dripwell with respect to the body (key 1).



WARNING

A regulator may vent some gas to the atmosphere. In hazardous or flammable gas service, vented gas may accumulate and cause personal injury, death, or property damage due to fire or explosion. Vent a regulator in hazardous gas service to a remote, safe location away from air intakes or any hazardous area. The vent line or stack opening must be protected against condensation or clogging.

5. A clogged spring case vent hole may cause the regulator to function improperly. To keep this vent hole from being plugged (and to keep the spring case from collecting moisture, corrosive chemicals, or other foreign material) orient the vent to the lowest possible point on the spring case or otherwise protect it. Inspect the vent hole regularly to make sure it is not plugged. Spring case vent hole orientation may be changed by rotating the spring case with respect to the body. A 1/4-inch NPT spring case vent may be remotely vented by installing tubing or piping into the vent.

6. For regulator shutdown, install upstream block and vent valves and downstream block and vent valves (if required), or provide some other suitable means of properly venting the regulator inlet and outlet pressures.

7. Apply a good grade of pipe compound to the male pipe threads before making connections, making sure not to get the pipe compound inside the regulator.

8. Install tubing fitting or piping into the 1/4-inch NPT inlet connection on the body (key 1) and into the 1/4-inch NPT body outlet connection.

9. The second 1/4-inch NPT outlet can be used for a gauge or other use. If not used, it must be plugged.



67CF Series

10. When installing a 67CF Series regulator in an existing installation, it may be necessary to use spacers to adapt the installation. If the mounting bolts are too long, place a spacer on the bolt. To be sure the regulator is secure, the bolts should have at least two full threads of engagement.

Startup and Adjustment

1. With proper installation completed and downstream equipment properly adjusted, slowly open the upstream and downstream shutoff valve (when used) while using pressure gauges to monitor pressure.



WARNING

To avoid personal injury, property damage, or equipment damage caused by bursting of pressure containing parts or explosion of accumulated gas, never adjust the control spring to produce an outlet pressure higher than the upper limit of the outlet pressure range for that particular spring. If the desired outlet pressure is not within the range of the control spring, install a spring of the proper range.

2. If outlet pressure adjustment is necessary, monitor outlet pressure with a gauge during the adjustment procedure. The regulator is adjusted by loosening the locknut (key 19), if used, and turning the adjusting screw or handwheel (key 18) clockwise to increase or counter-clockwise to decrease the outlet pressure setting. Tighten the locknut to maintain the adjustment position.

Parts List

Key	Description	Key	Description
1	Body	16 ⁽¹⁾	Diaphragm Assembly
2	Drain Valve	17	Spring
3	Flange Screw	18	Adjusting Screw
4 ⁽¹⁾	O-Ring	19	Locknut
5	Dripwell	20	Upper Spring Seat
6 ⁽¹⁾	Filter Element	22	Pressure Gauge
7	Spring Case	23	1/4-Inch Pipe Plug
9	Filter Retainer	24	Tire Valve
10 ^(1,2)	Valve Cartridge	26 ⁽¹⁾	Filter Gasket
11 ^(1,2)	Valve Plug	31	Panel Mounting Nut
12 ^(1,2)	Valve Spring	32	Wire Seal
13 ^(1,2)	Valve Retainer	33	Closing Cap
14 ^(1,2)	O-Ring	34	Spacer
15 ^(1,2)	Soft Seat		

1. Recommended Spare Part
 2. Valve cartridge assembly includes keys 10, 11, 12, 13, 14, and 15.

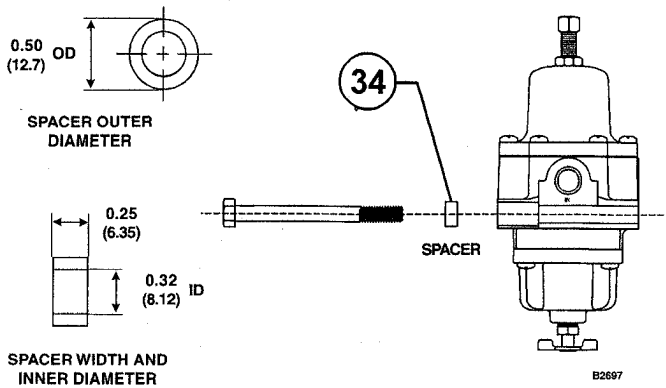

Figure 1. Spacer Diameter and Installation

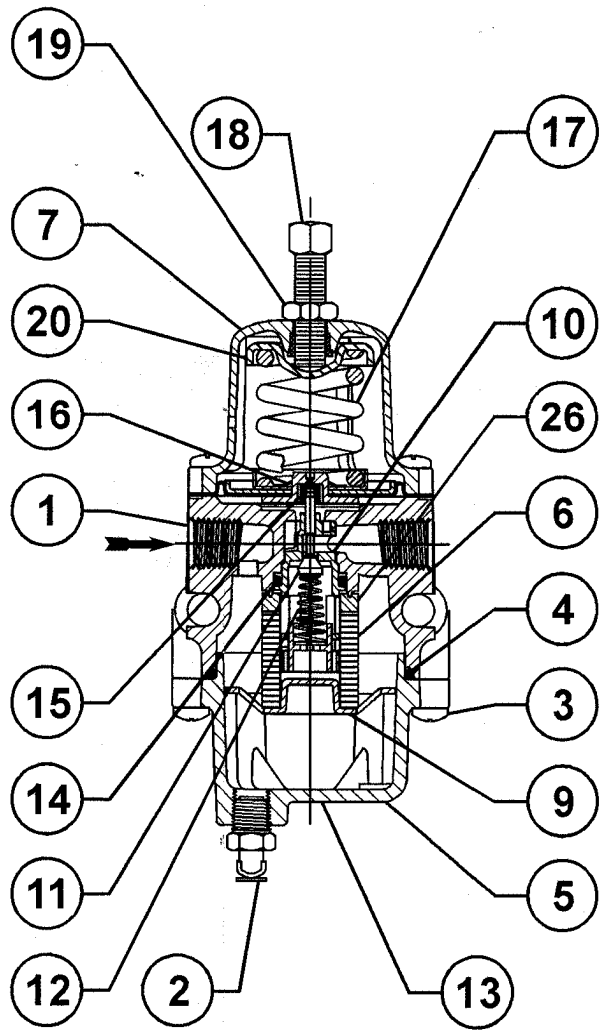

Figure 2. 67CF Series Assembly Drawings

©Fisher Controls International, Inc., 1999; All Rights Reserved

Fisher and Fisher Regulators are marks owned by Fisher Controls International, Inc. The Emerson logo is a trade mark and service mark of Emerson Electric Co. All other marks are the property of their respective owners.

The contents of this publication are presented for informational purposes only, and while every effort has been made to ensure their accuracy, they are not to be construed as warranties or guarantees, express or implied, regarding the products or services described herein or their use or applicability. We reserve the right to modify or improve the designs or specifications of such products at any time without notice.

For information, contact Fisher Controls:

Marshalltown, Iowa 50158 USA
 28320 Gallardon, France
 Sao Paulo 05424 Brazil
 Singapore 128461

Printed in U.S.A.

www.FISHERregulators.com

