

# Shock/Vibration Control Switches Installation Instructions

Models: VS2, VS2C, VS2EX, VS2EXR, VS2EXRB and VS94



Please read the following instructions before installing. A visual inspection of this product for damage during shipping is recommended before mounting. It is your responsibility to have a qualified person install the unit, and make sure installation conforms with NEC and local codes.

## GENERAL INFORMATION

### WARNING

BEFORE BEGINNING INSTALLATION OF THIS MURPHY PRODUCT

- ✓ Disconnect all electrical power to the machine.
- ✓ Make sure the machine cannot operate during installation.
- ✓ Follow all safety warnings of the machine manufacturer.
- ✓ Read and follow all installation instructions.



Model VS2EX

### Description

The Murphy shock and vibration switches are available in a variety of models for applications on machinery or equipment where excessive vibration or shock can damage the equipment or otherwise poses a threat to safe operation. A set of contacts is held in a latched position through a mechanical latch and magnet mechanism. As the level of vibration or shock increases an inertia mass exerts force against the latch arm and forces it away from the magnetic latch causing the latch arm to operate the contacts. Sensitivity is obtained by adjusting the amount of the air gap between the magnet and the latch arm plate.

Applications include all types of rotating or reciprocating machinery such as cooling fans, engines, pumps, compressors, pump jacks, etc.

### Models

**VS2:** Base mount; non hazardous locations.

**VS2C:** C-clamp mount; non hazardous locations.

**VS2EX:** Explosion-proof; Class I, Div. 1, Groups C and D.

**VS2EXR:** Explosion-proof with remote reset.

**VS2EXRB:** Explosion-proof; Class I, Div. 1, Group B; with remote reset.

**VS94:** Base mount; non hazardous locations, NEMA 4X/IP66.

### Remote Reset Feature (VS2EXR, VS2EXRB and VS94 only)

Includes built-in electric solenoid which allows reset of tripped unit from a remote location. Standard on VS2EXR and VS2EXRB. Optional on VS94 (options listed below).

**-R15:** Remote reset for 115 VAC

**-R24:** Remote reset for 24 VDC

### Time Delay Option (VS94 only)

Overrides trip operation on start-up. For VS94 series models, the delay time is field-adjustable from 5 seconds up to 100 seconds with a 20-turn potentiometer (5 seconds per turn approximately). Options listed below:

**-T15:** Time delay for 115 VAC

**-T24:** Time delay for 24 VDC

### Space Heater Options (VS94 only)

This optional space heater board prevents moisture from condensing inside the VS94 Series case. Options listed below:

**-H15:** Space heater for 115 VAC

**-H24:** Space heater for 24 VDC

### Warranty

A limited warranty on materials and workmanship is given with this FW Murphy product. A copy of the warranty may be viewed or printed by going to [www.fwmurphy.com/support/warranty.htm](http://www.fwmurphy.com/support/warranty.htm)

# DIMENSIONS

## VS2

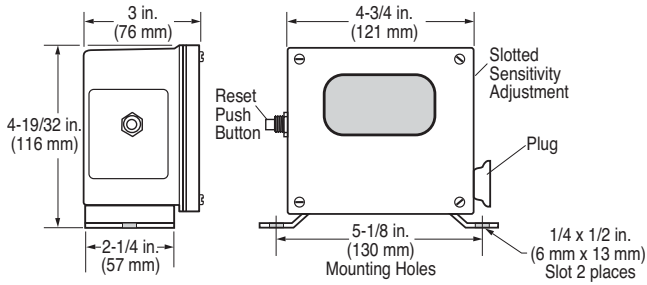

## VS2C

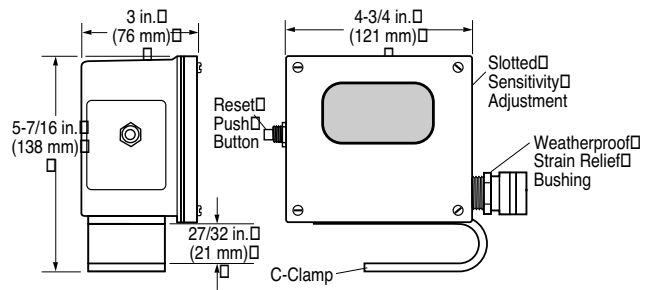

## VS2EX and VS2EXR

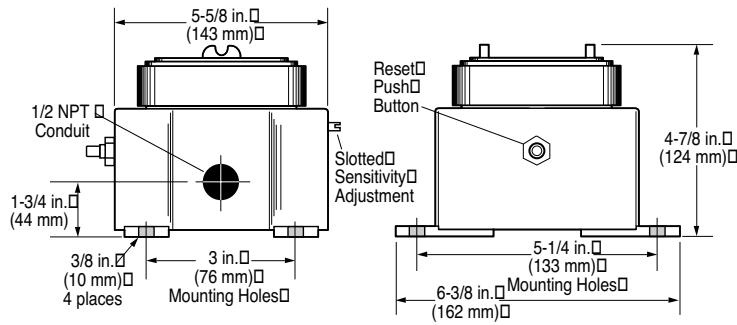

## VS2EXRB

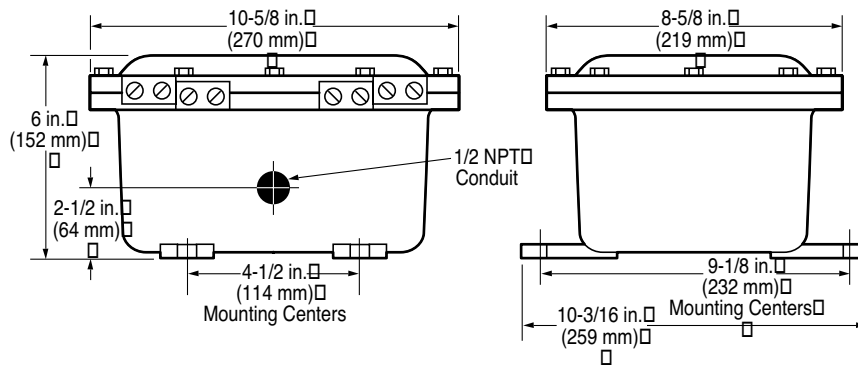

## VS94

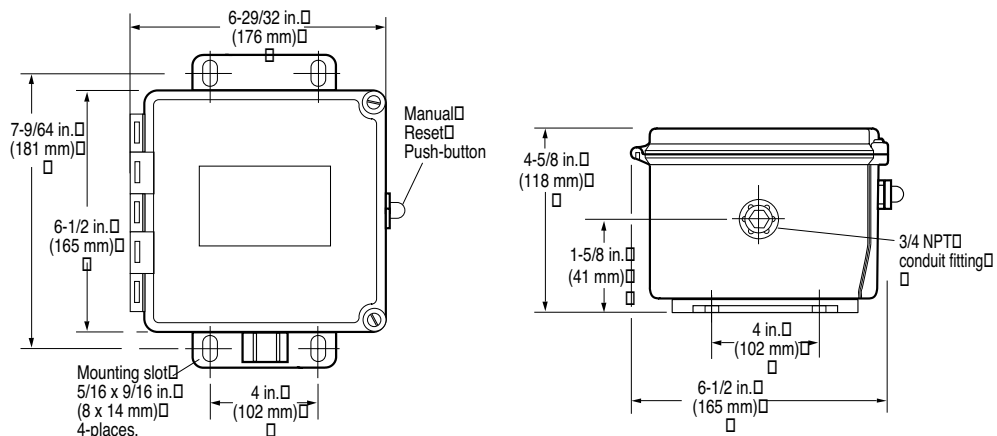

## SPECIFICATIONS

### VS2 and VS2C

- **Case:** Weatherproof (equal to NEMA 3R) suitable for non-hazardous areas.  
VS2: *Base mount*  
VS2C: *C-clamp mount. Includes 45 feet (13.7 meters), 2-conductor 16 AWG, 30 strands/0.25 mm strand dia. (1.5 mm<sup>2</sup>) cable, and five cable hold down clamps.*
- **Contacts:** SPDT double make leaf contacts, 5A @ 480 VAC.
- **Range adjustment:** 0 - 7 G's; 0 - 100 Hz /0.100 in. displacement.

### VS2EX

- **Case:** Explosion-proof and weatherproof aluminum alloy housing; meets NEMA 7/IP50 specifications; Class I, Division 1, Groups C & D; UL and CSA listed.\*  
VS2EX: *base mount.*
- **Snap-switches:** 2-SPDT snap-switches; 5A @ 480 VAC;\* 2A resistive, 1A inductive, up to 30 VDC.
  - **Range adjustment:** 0 - 7 G's; 0 - 100 Hz /0.100 in. displacement.
- **Normal Operating Temperature:** -40 to 140°F (-40 to 60°C).

### VS2EXR

- **Case:** Same as VS2EX.
- **Snap-switch:** 1-SPDT snap-switch and reset coil; 5A @ 480 VAC;\* 2A resistive, 1A inductive, up to 30 VDC.
- **Remote Reset (optional):**

<i>Option</i>	<i>Operating Current</i>
-R15:	350 mA @ 115 VAC
-R24:	350 mA @ 24 VDC
- **Range adjustment:** 0 - 7 G's; 0 - 100 Hz /0.100 in. displacement.
- **Normal Operating Temperature:** -40 to 140°F (-40 to 60°C).

### VS2EXRB

- **Case:** Explosion-proof aluminum alloy housing; rated Class I, Division 1, Group B hazardous areas.
- **Snap-switch:** 1-SPDT snap-switch with reset coil (option available for

additional SPDT switch); 5A @ 480 VAC; 2A resistive, 1A inductive, up to 30 VDC.

#### • Remote Reset:

##### *Option Operating Current*

-R15: 350 mA @ 115 VAC

-R24: 350 mA @ 24 VDC

- **Range adjustment:** 0 - 7 G's; 0 - 100 Hz /0.100 in. displacement.

### VS94

- **Case:** Polyester fiberglass reinforced; NEMA type 4 and 4X; IP66; CSA types 4 and 12.
- **Conduit Fitting:** 3/4 NPT conduit fitting connection.
- **Normal Operating Ambient Temperature:** 0 to 140°F (-18 to 60°C).
- **Snap-switches:** 2-SPDT snap acting switches; 5A @ 480 VAC; 2A resistive, 1A inductive, up to 30 VDC.
- **Range adjustment:** 0 - 7 G's; 0 - 100 Hz /0.100 in. displacement.
- **Heater (optional):**

<i>Option</i>	<i>Operating Current</i>
H15	.023 A @ 115 VAC
H24	.12 A @ 24 VDC
- **Remote Reset (optional):**

<i>Option</i>	<i>Operating Current</i>
R15	.17 A @ 115 VAC
R24	.36 A @ 24 VDC
- **Time Delay (optional):**

<i>Option</i>	<i>Operating Current</i>	<i>Standby Current</i>
T15	.360 A @ 115 VAC	.01 A @ 115 VAC
T24	1.15 A @ 24 VDC	.01 A @ 24 VDC
- **Time Delay/Remote Reset:** Adjustable 20-turn potentiometer from 5 seconds to 100 seconds (5 seconds per turn approximately).

\*CSA and UL listed with 480 VAC rating.

## INSTALLATION



**WARNING: STOP THE MACHINE AND DISCONNECT ALL ELECTRICAL POWER BEFORE BEGINNING INSTALLATION.**

The VS2 and VS94 series shock switches are sensitive to shock and vibration in all three planes of motion - up/down, front/back and side/side. Front/back is the most sensitive (The reset pushbutton is located on the "front" of the unit). For maximum sensitivity mount the unit so that the front faces into the direction of rotation of the machine. (See Dimensions on page 2 for sensitivity adjustment location).

The VS2 and VS94 Series must be firmly attached/mounted to the machine so that all mounting surfaces are in rigid contact with the mounting surface of the machine. For best results, mount the instrument in-line with the direction of rotating shafts and/or near bearings. In other words, the reset push button should be mounted pointing into the direction of shaft rotation (see page 5). It may be necessary to provide a mounting plate or bracket to attach the VS2 and VS94 Series to the machine. The mounting bracket should be thick enough to prevent induced acceleration/vibration upon the VS2 or VS94 Series. Typically 1/2 in. (13mm) thick plate is sufficient. See illustrations on page 5 for typical mounting locations.



**CAUTION:** A dust boot is provided on the reset pushbutton for all series to prevent moisture or dust intrusion. The sensitivity adjustment for model VS2EX is not sealed; therefore, mounting

orientation should be on a horizontal plane or with the sensitivity adjustment pointing down. Sensitivity adjustment for model VS2 is covered by a plug. The plug must be in place and tight to prevent moisture or dust intrusion.

### C-Clamp Installation (VS2C model only)

A C-Clamp is supplied with the VS2C model only. The C-Clamp is shipped installed on the VS2C but must be installed on the VS2EX and VS2EXR switches.

1. The C-Clamp (B) will already be installed on a 1/4 in. (6 mm) thick steel mounting plate (A). Bolt the VS2 switch to the mounting plate as illustrated — with four 5/16 in. bolts, nuts, and washers.
2. The mounting location should provide convenient access to the TATTLETALE® push button (C).
3. The hardened set screw and nuts (D) are used to tighten the switch to an I-Beam or cross member such as a Sampson post of an oilwell pumpjack.

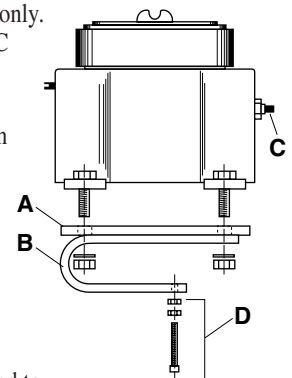

*Continued on next page.*

## All Models



**WARNING: STOP THE MACHINE AND DISCONNECT ALL ELECTRICAL POWER BEFORE BEGINNING INSTALLATION.**

1. Firmly secure the unit to the equipment using the base foot mount or C-Clamp if applicable. See *C-Clamp Installation* page 3.  
For oilwell pumpjacks attach the VS2 and VS94 Series to the Sampson post or walking beam. See *Typical Mounting Locations* page 5.
2. Make the necessary electrical connections to the vibration switch. See *Internal Switches*, page 6 for electrical terminal locations and page 7 for typical wiring diagrams. **DO NOT EXCEED VOLTAGE OR CURRENT RATINGS OF THE CONTACTS.** Follow appropriate electrical codes/methods when making electrical connections. Be sure that the run of electrical cable is secured to the machine and is well insulated from electrical shorting. Use of conduit is recommended.

**NOTE: If the electrical cable crosses a pivot point such as at the pivot of the walking beam, be sure to allow enough slack in the cable so that no stress is placed on the cable when the beam moves.**

If conduit is not used for the entire length of wiring, conduit should be used from the electrical supply box to a height above ground level that prevents damage to the exposed cable from the elements, rodents, etc. or as otherwise required by applicable electrical codes. If conduit is not attached directly to the VS2 and VS94 Series switch, use a strain relief bushing and a weatherproof cap on the exposed end of the conduit. A “drip loop” should be provided in the cable to prevent moisture from draining down the cable into the conduit should the weathercap fail.

## Sensitivity Adjustment



**WARNING: REMOVE ALL POWER BEFORE OPENING THE ENCLOSURE. IT IS YOUR RESPONSIBILITY TO HAVE A QUALIFIED PERSON PERFORM ADJUSTMENTS, AND MAKE SURE IT CONFORMS WITH NEC AND LOCAL CODES. DO NOT ADJUST SENSITIVITY WHILE THE MACHINE IS RUNNING. STAND CLEAR OF THE MACHINE AT ALL TIMES WHEN IT IS OPERATING.**

All models of the VS2 and VS94 Series cover a wide range of sensitivity. Each model is adjusted to the specific piece of machinery on which it is installed. After the switch has been installed in a satisfactory location (see page 5) the sensitivity adjustment will be increased or decreased so that the switch does not trip during start-up or under normal operating conditions. This is typically done as follows:

1. **REPLACE ALL COVERS, LIDS, AND ELECTRICAL ENCLOSURES.**
2. Press the reset push button to engage the magnetic latch. To be sure the magnetic latch has engaged, observe latch through the window on the VS2 and VS2C (see DETAIL “A”). On the VS2EX, VS94 series the reset button will remain depressed meaning the magnetic latch has engaged.
3. Start the machine.
4. If the instrument trips on start-up,

**DETAIL “A”**

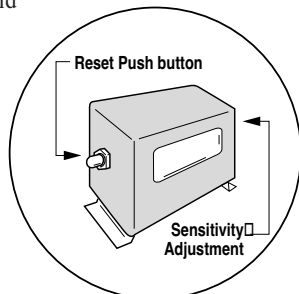

allow the machine to stop. Turn the sensitivity adjustment 1/4 turn clockwise, (adjustment for VS94 and VS2EXRB models is located within the box, see DETAIL “B”).



**WARNING: MAKE THE AREA NON-HAZARDOUS BEFORE OPENING THE EXPLOSION-PROOF (-EX) ENCLOSURES.**

Depress the reset button and restart the machine. Repeat this process until the unit does not trip on start-up.

**DETAIL “B”**

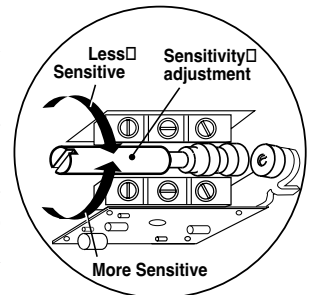

5. If the instrument does NOT trip on start-up, stop the machine. Turn the sensitivity adjustment 1/4 turn counter-clockwise. Repeat the start-up/stop process until the instrument trips on start-up. Turn the sensitivity adjustment 1/4 turn clockwise (less sensitive). Restart the machine to verify that the instrument will not trip on start-up.

6. Verify that the unit will trip when abnormal shock/vibration exists.

## VS94 Time Delay Adjustment

1. Apply power to the time delay circuit. (see page 7 for time delay circuit). The time delay function will be initiated.
2. Time the length of the delay with a watch. Let time delay expire. After it expires, the override circuit will de-energize the solenoid, allowing the latch arm to trip. A clicking noise is heard.



**WARNING: REMOVE ALL POWER BEFORE OPENING ACCESS DOOR. IT IS YOUR RESPONSIBILITY TO HAVE A QUALIFIED PERSON ADJUST THE UNIT, AND MAKE SURE IT CONFORMS WITH NEC AND LOCAL CODES.**

3. **TURN THE POWER OFF TO RESET THE TIME DELAY CIRCUIT.**

**NOTE: Allow 30 seconds bleed-time between turning the power “OFF” and “ON”**

4. Locate the time adjustment pot (DETAIL “C”). The time is factory-set at the lowest setting (5 seconds approximately). To increase time, rotate the 20-turn pot clockwise as needed (5 seconds per turn approximately).

**DETAIL “C”**

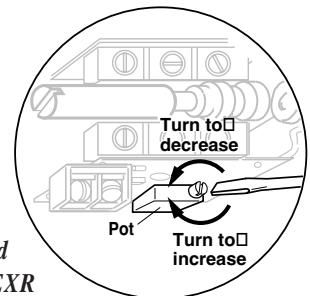

5. Repeat the above steps as necessary to obtain desired time delay.

**NOTE: An external time delay can be used with the remote reset feature of the VS2EXR series to provide a remote reset and override of the trip operation on start-up. Time delay must automatically disconnect after equipment start-up.**

## TYPICAL MOUNTING LOCATIONS

**NOTE:** These are typical mounting locations for best operation. Other mountings are possible. See *Installation* section on page 3.

### 2-Throw Balance-Opposed Compressor

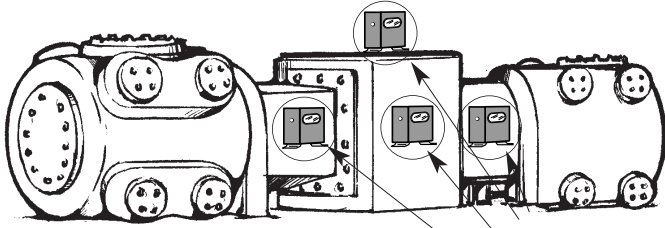

**NOTE:** If installing on cylinders, 2 vibration/shock switches are recommended- 1 for each cylinder.

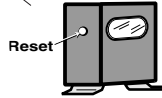

### Pumping Unit

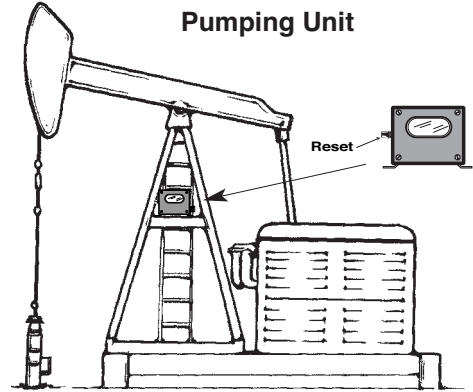

### Engine and Vertical Shaft Pump

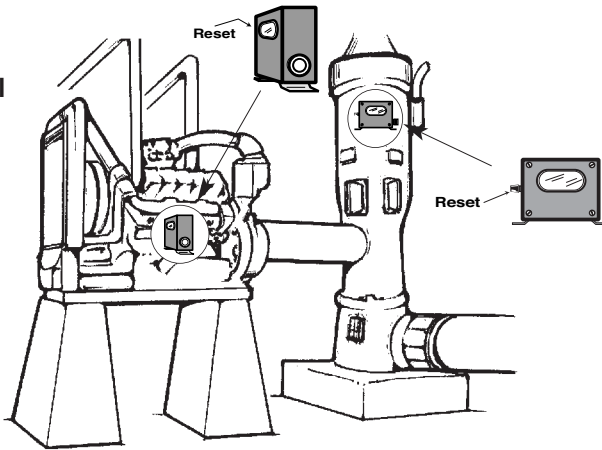

### "Y" Type Reciprocating Compressor

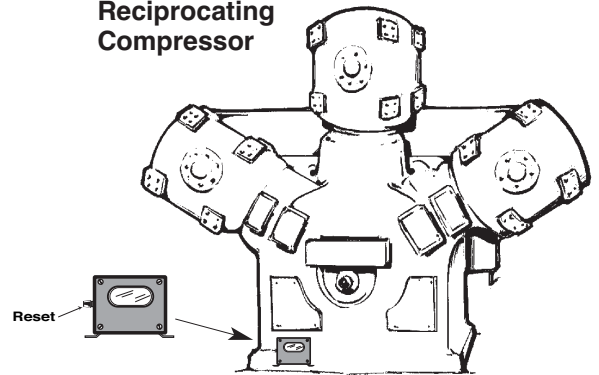

### Generator Sets

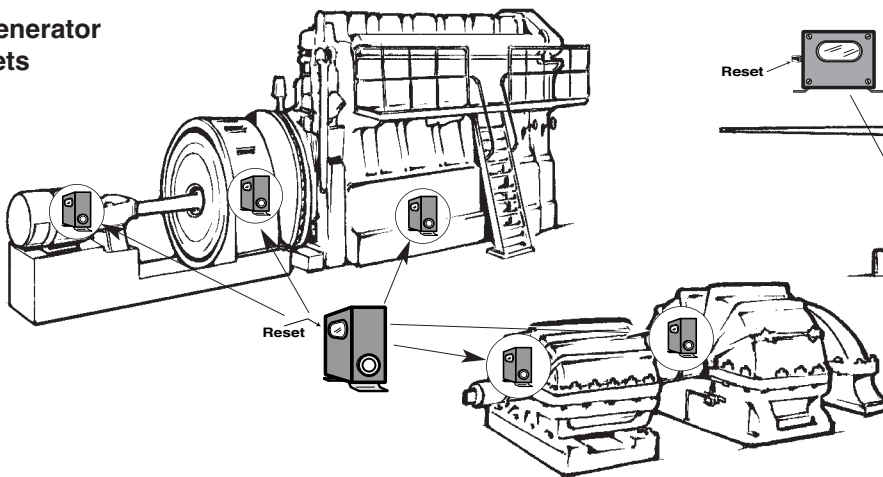

### Cooling Tower Fan or Heat Exchanger

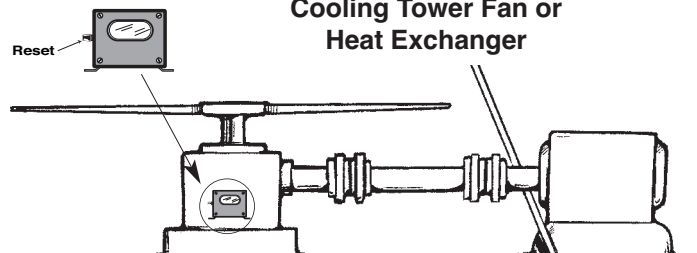

### Engine Compressor

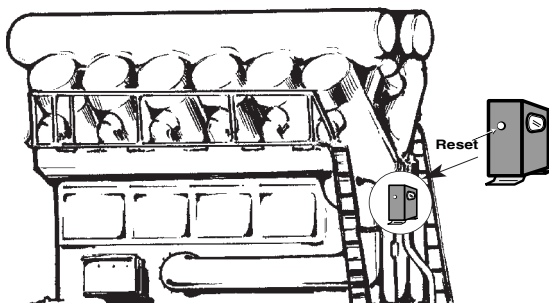

### Turbine Centrifugal Compressor

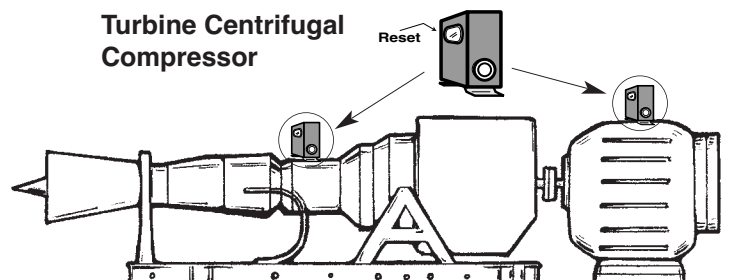

# INTERNAL SWITCHES

VS2 and VS2C

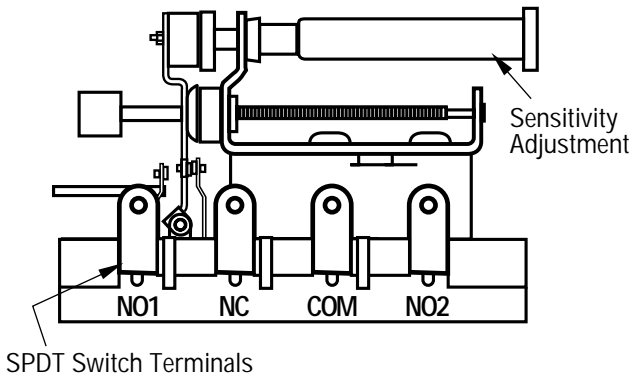

VS2EXR

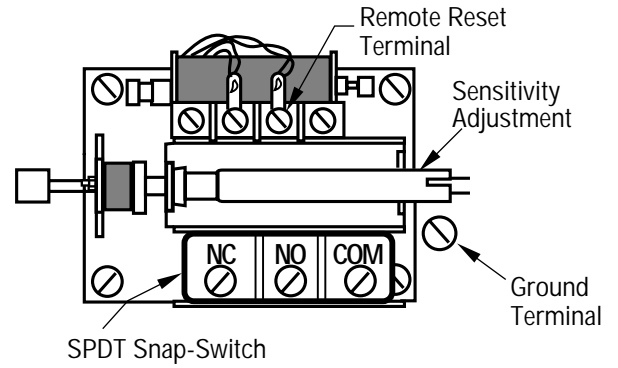

VS2EX

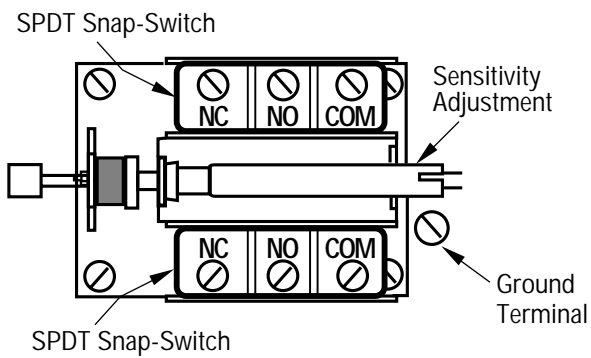

VS2EXB and VS2EXRB

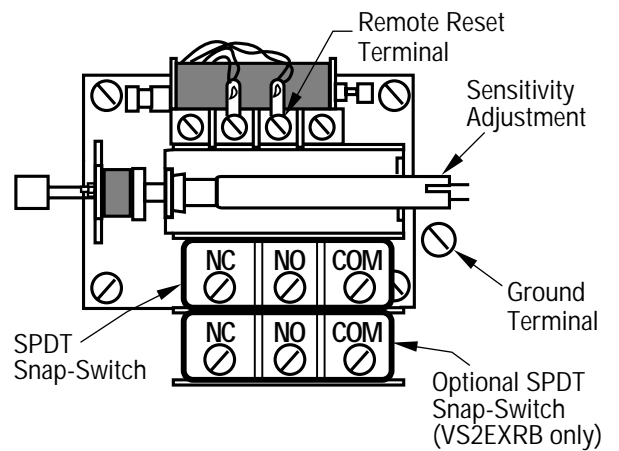

VS94

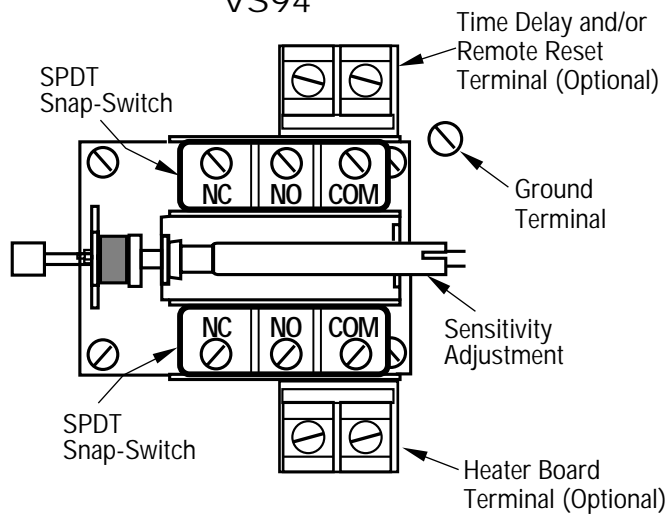

# ELECTRICAL



**WARNING: REMOVE POWER BEFORE OPENING THE UNIT (ACCESS DOOR). STOP THE MACHINE AND DISCONNECT ALL ELECTRICAL POWER BEFORE BEGINNING THE WIRING OPERATION. IT IS YOUR RESPONSIBILITY TO HAVE A QUALIFIED PERSON INSTALL AND WIRE THE UNIT, AND MAKE SURE IT CONFORMS WITH NEC AND APPLICABLE CODES.**

**VS2 and VS2C**  
Typical Wiring Diagram for Single or Dual CD Ignition

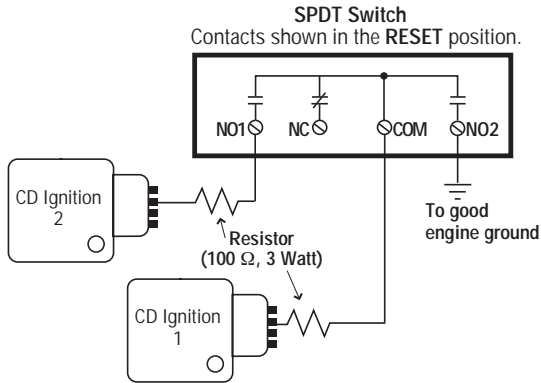

**VS2EX**  
Typical Wiring Diagram for Single or Dual CD Ignitions

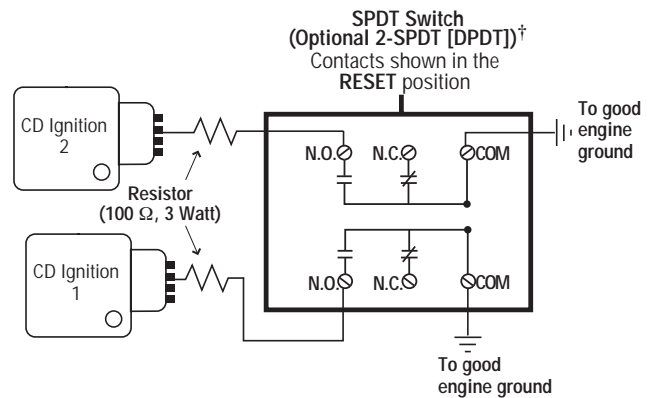

**VS2EXR and VS2EXRB**  
Typical Wiring Diagram for Single or Dual CD Ignitions

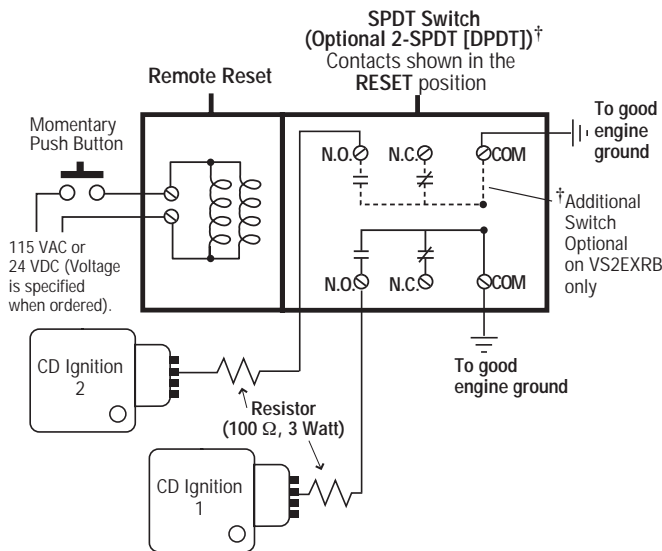

**VS94**  
Typical Wiring Diagram for Single or Dual CD Ignitions

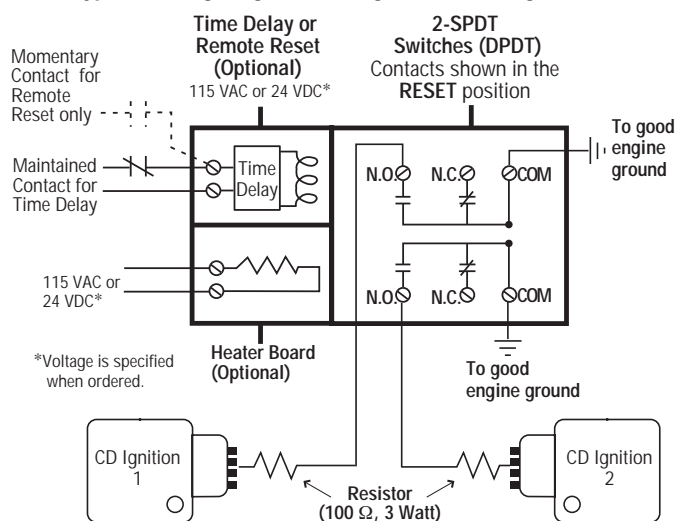

**VS2, VS2C, VS2EX, VS2EXR, VS2EXRB and VS94**  
Typical Wiring Diagram for Electric Motors

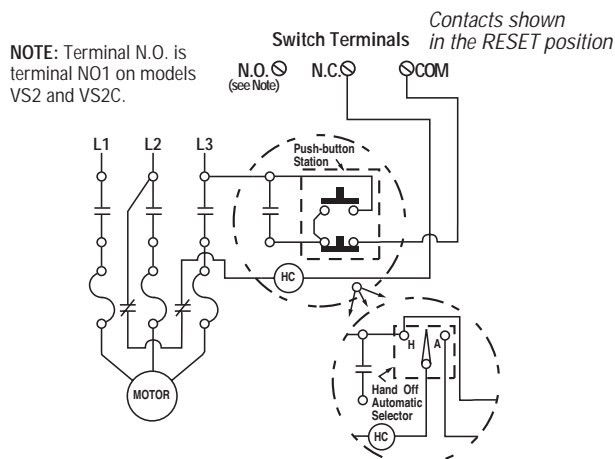

**VS2, VS2C, VS2EX, VS2EXR, VS2EXRB and VS94**  
Typical Wiring Diagram for Distributor Ignition or Diesel

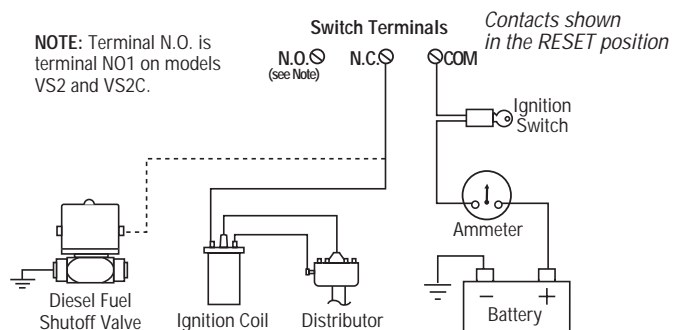

## SERVICE PARTS

### PART NO. DESCRIPTION

#### VS2

20000030 Movement assembly  
 20000031 Glass and gasket assembly  
 20000032 Reset push button assembly

#### VS2C

20000030 Movement assembly  
 20000031 Glass and gasket assembly  
 20000032 Reset push button assembly  
 20050021 Mounting clamp  
 20000185 VS2C 5-clamp hardware package assembly.  
 20050465 2-Conductor electrical cable, 45 feet (13.7 meters)

#### VS2EX

20010091 Movement assembly  
 20050087 Cover  
 00000309 Cover gasket  
 20010090 Snap-switch and insulator kit (1 switch per kit)  
**prior to September 1, 1995.\***  
**20000288 Snap-switch and insulator kit (1 switch per kit) for models  
 manufactured on September 1, 1995 or later.\***  
 20000289 C-clamp conversion mounting kit

#### VS2EXR

20000262 Movement assembly  
 20050087 Cover  
 00000309 Cover gasket  
 20010090 Snap-switch and insulator kit (1 switch per kit)  
**prior to September 1, 1995.\***  
**20000288 Snap-switch and insulator kit (1 switch per kit) for models  
 manufactured on September 1, 1995 or later.\***  
 20000049 Reset solenoid assembly (115 VAC)  
 20000234 Reset solenoid assembly (24 VDC)  
 20000289 C-clamp conversion mounting kit

### PART NO. DESCRIPTION

#### VS2EXRB

20010090 Snap-switch and insulator kit (1 switch per kit)  
**prior to September 1, 1995.\***  
**20000288 Snap-switch and insulator kit (1 switch per kit) for models  
 manufactured on September 1, 1995 or later.\***  
 20000057 *Inside* snap-switch and insulator kit (1 switch per kit) for  
 model VS2EXRB-D **prior to September 1, 1995.\***  
 20000058 *Outside* snap-switch and insulator kit (1 switch per kit) for  
 model VS2EXRB-D **prior to September 1, 1995.\***  
**20000287 Outside snap-switch and insulator kit (1 switch per kit) for model  
 VS2EXRB-D manufactured on September 1, 1995 or later.\***  
**20000290 Inside snap-switch and insulator kit (1 switch per kit) for model  
 VS2EXRB-D manufactured on September 1, 1995 or later.\***  
 20050077 Adjustment shaft  
 20000262 Movement assembly  
 20000049 Reset solenoid assembly (115 VAC)  
 20000234 Reset solenoid assembly (24 VDC)

#### VS94 Series

25050506 Dust boot  
 00000232 Conduit fitting  
 20010090 Snap-switch and insulator kit (1 switch per assembly)  
**prior to September 1, 1995.\*\***  
**20000288 Snap-switch and insulator kit (1 switch per assembly)  
 for models manufactured on September 1, 1995 or later.\*\*\***

\* If no date code is found, refer to the old switch. Models with date 0895 and before use old switch.  
 Dated 0995 after, use straight snap-switch arm, no rollers.

\*\* Models dated Q1 thru Q8 (formed snap-switch arm and rollers).

\*\*\*Models date coded Q9 thru Q12 and R1 thru R12 (straight snap-switch arm, no rollers).

#### FW MURPHY

P.O. Box 470248  
 Tulsa, Oklahoma 74147 USA  
 +1.918.317.4100 Fax: +1.918.317.4266  
 E-mail: sales@fwmurphy.com

#### INDUSTRIAL PANEL DIVISION

Fax: 918.317.4124  
 E-mail: ipdsales@fwmurphy.com

#### MURPHY POWER IGNITION

Web site: www.murphy-pi.com

**www.fwmurphy.com**

#### CONTROL SYSTEMS & SERVICES DIVISION

P.O. Box 1819  
 Rosenberg, Texas 77471 USA  
 Phone: 281.633.4500 Fax: 281.633.4588  
 E-mail: sales@fwmurphy.com  
 Web site: www.fwmurphy.com

#### FRANK W. MURPHY, LTD

Church Rd Laverstock  
 Salisbury SP1 1QZ UK  
 Phone: +44 1722 410055 Fax: +44 1722 410088  
 E-mail: sales@fwmurphy.co.uk  
 Web site: www.fwmurphy.co.uk

#### COMPUTRONIC CONTROLS, LTD

41 - 43 Railway Terrace Nechells  
 Birmingham B7 5NG UK  
 Phone: +44 121 327 8500 Fax: +44 121 327 8501  
 E-mail: info@computroniccontrols.com  
 Web site: www.computroniccontrols.com

#### FW MURPHY INSTRUMENTS (HANGZHOU) CO. LTD

77 23rd Street  
 Hangzhou Economic & Technological Development Area  
 Hangzhou, Zhejiang, 310018, China  
 Phone: +86 571 8684 8886 Fax: +86 571 8684 8878



Printed in U.S.A. 078792

*In order to consistently bring you the highest quality, full featured products, we reserve the right to change our specifications and designs at any time.*